

# **ESP-12F Datasheet**

# 1. Product overview

The ESP-12F WiFi module was developed by Ai-Thinker Technology. The core processor ESP8266 integrates the industry-leading Tensilica L106 ultra-low-power 32-bit micro MCU in a small package with 16-bit Lite mode, clocked at Supports 80 MHz and 160 MHz, supports RTOS, and integrates Wi-Fi MAC/BB/RF/PA/LNA.

The ESP-12F WiFi module supports the standard IEEE802.11 b/g/n protocol, a complete TCP/IP protocol stack. Users can use this module to add networking capabilities to existing devices or to build separate network controllers.

The ESP8266 is a high-performance wireless SOC that offers maximum utility at the lowest cost and unlimited possibilities for embedding WiFi functionality into other systems.

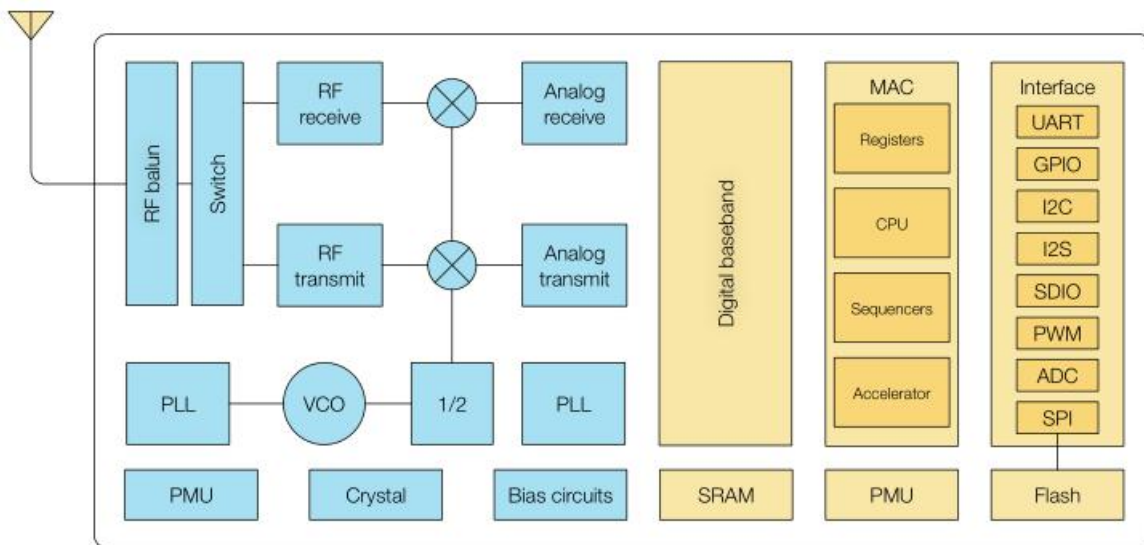

The ESP8266 is a complete and self-contained WiFi network solution that can operate independently or as a slave running on other host MCUs. The ESP8266 is capable of booting directly from an external flash memory when it is powered by an application and is the only application processor in the device. The built-in cache helps improve system performance and reduce memory requirements.

In another case, the ESP8266 is responsible for wireless Internet access. When it comes to the task of the WiFi adapter, it can be added to any micro controller-based design. The connection is simple and easy, just by SPI / SDIO interface or I2C / UART port. Just fine.

The ESP8266's powerful on-chip processing and storage capabilities allow it to integrate sensors and other application-specific devices through the GPIO port, minimizing system resources during minimal up-front development and operation.



## Features

- The smallest 802.11b/g/n Wi-Fi SOC module
- Low power 32-bit CPU, can also serve as the application processor
- Up to 160MHz clock speed
- Built-in 10 bit high precision ADC
- Supports UART/GPIO/IIC/PWM/ADC
- SMD-22 package for easy welding
- Integrated Wi-Fi MAC/BB/RF/PA/LNA
- Support multiple sleep patterns. Deep sleep current as low as 20uA
- UART baud rate up to 4Mbps
- Embedded LWIP protocol stack
- Supports STA/AP/STA + AP operation mode
- Support Smart Config/AirKiss technology
- Supports remote firmware upgrade (FOTA)
- General AT commands can be used quickly
- Support for the two development, integration of windows, Linux development environment

# Product Specification

Table1.1 Product Specification Description

<b>Module Model</b>	<b>ESP-12F</b>
<b>Package</b>	<b>SMD22</b>
<b>Size</b>	<b>24*16*3(± 0.2)mm</b>
<b>Certification</b>	<b>FCC、CE、IC、REACH、RoHS</b>
<b>SPI Flash</b>	<b>Default 32Mbit</b>
<b>Interface</b>	<b>UART/GPIO/ADC/PWM</b>
<b>IO Port</b>	<b>9</b>
<b>UART Baud rate</b>	<b>Support 300 ~ 4608000 bps , Default 115200 bps</b>
<b>Frequency Range</b>	<b>2412 ~ 2484MHz</b>
<b>Antenna</b>	<b>PCB Antenna</b>
<b>Transmit Power</b>	<b>802.11b: 16±2 dBm (@11Mbps) 802.11g: 14±2 dBm (@54Mbps) 802.11n: 13±2 dBm (@HT20, MCS7)</b>
<b>Receiving Sensitivity</b>	<b>CCK, 1 Mbps : -90dBm CCK, 11 Mbps: -85dBm 6 Mbps (1/2 BPSK): -88dBm 54 Mbps (3/4 64-QAM): -70dBm HT20, MCS7 (65 Mbps, 72.2 Mbps): -67dBm</b>
<b>Power (Typical Values)</b>	<b>Continuous Transmission=&gt;Average: ~71mA, Peak: 500mA Modem Sleep: ~20mA Light Sleep: ~2mA Deep Sleep: ~0.02mA</b>
<b>Security</b>	<b>WEP/WPA-PSK/WPA2-PSK</b>
<b>Power Supply</b>	<b>Voltage 3.0V ~ 3.6V, Typical 3.3V, Current &gt;500mA</b>
<b>Operating Temperature</b>	<b>-20 °C ~ 85 °C</b>
<b>Storage Environment</b>	<b>-40 °C ~ 85 °C , &lt; 90%RH</b>

## 2. Pin Definition

The ESP-12 module leads to 16 pins.

Figure 2.1 ESP-12F Pin diagram

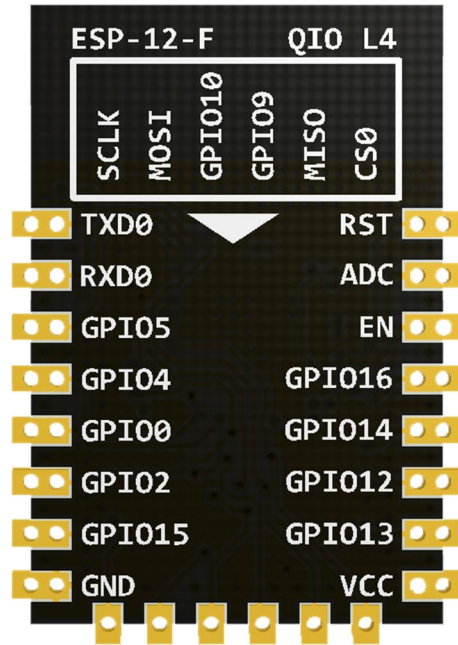

Table 2.2 Pin function description

No.	Pin Name	Functional Description
1	RST	Reset Pin, Active Low
2	ADC	AD conversion, Input voltage range 0~1V, the value range is 0~1024.
3	EN	Chip Enabled Pin, Active High
4	IO16	Connect with RST pin to wake up Deep Sleep
5	IO14	GPIO14; HSPI_CLK
6	IO12	GPIO12; HSPI_MISO
7	IO13	GPIO13; HSPI_MOSI; UART0_CTS

<b>8</b>	<b>VCC</b>	<b>Module power supply pin, Voltage 3.0V ~ 3.6V</b>
<b>9</b>	<b>GND</b>	<b>GND</b>
<b>10</b>	<b>IO15</b>	<b>GPIO15; MTDO; HSPICS; UART0_RTS</b>
<b>11</b>	<b>IO2</b>	<b>GPIO2; UART1_TXD</b>
<b>12</b>	<b>IO0</b>	<b>GPIO0;HSPI_MISO;I2SI_DATA</b>
<b>13</b>	<b>IO4</b>	<b>GPIO4</b>
<b>14</b>	<b>IO5</b>	<b>GPIO5;IR_R</b>
<b>15</b>	<b>RXD</b>	<b>UART0_RXD; GPIO3</b>
<b>16</b>	<b>TXD</b>	<b>UART0_TXD; GPIO1</b>

Table 2.3 Description of the ESP series module boot mode

<b>Mode</b>	<b>CH_PD(EN)</b>	<b>RST</b>	<b>GPIO15</b>	<b>GPIO0</b>	<b>GPIO2</b>	<b>TXD0</b>
<b>Download mode</b>	<b>high</b>	<b>high</b>	<b>low</b>	<b>low</b>	<b>high</b>	<b>high</b>
<b>Running mode</b>	<b>high</b>	<b>high</b>	<b>low</b>	<b>high</b>	<b>high</b>	<b>high</b>

**Notes:** Some of the pins inside the module have been pulled or pulled down, please refer to the schematic diagram.

### 3. Electrical Characteristics

#### Electrical Characteristics

Parameter	Symbol	Min	Typ	Max	Unit	
Storage temperature	-	-40	Normal	85	°C	
Operating temperature	-	-20	20	85	°C	
Maximum soldering temperature	IPC/JEDEC J-STD-020	-	-	260	°C	
Supply voltage	VDD	2.7	3.3	3.6	V	
I/O	V <sub>IL</sub> /V <sub>IH</sub>	-	-0.3/0.75V <sub>IO</sub>	-	0.25V <sub>IO</sub> /3.6	V
	V <sub>OL</sub> /V <sub>OH</sub>	-	N/0.8V <sub>IO</sub>	-	0.1V <sub>IO</sub> /N	V
	I <sub>MAX</sub>	-	-	-	12	V



## Wi-Fi Radio

Description	Min	Typ	Max	Unit
Input frequency	2400	-	2483.5	MHz
Input reflection	-	-	-10	dB
<b>Output Power</b>				
PA output power at 72.2 Mbps	15.5	16.5	17.5	dBm
PA output power in 11b mode	19.5	20.5	21.5	dBm
<b>Sensitivity</b>				
CCK, 1 Mbps		-90		dBm
CCK, 11 Mbps		-85		dBm
6 Mbps (1/2 BPSK)		-88		dBm
54 Mbps (3/4 64-QAM)		-70		dBm
HT20, MCS7 (65Mbps,72.2 Mbps)		-67		dBm
<b>Adjacent channel rejection</b>				
OFDM, 6 Mbps		37		dB
OFDM, 54 Mbps		21		dB
HT20, MCS0		37		dB
HT20, MCS7		20		dB

## Power Consumption

The following power consumption data were obtained from the tests with a 3.3V power supply and a voltage stabilizer, in 25°C ambient temperature. All data are based on 50% duty cycle in continuous transmission mode.

Modes	Min	Typ	Max	Unit
<b>Tx 802.11b, CCK 11Mbps, POUT=+17dBm</b>	-	170	-	mA
<b>Tx 802.11g, OFDM 54Mbps, POUT =+15dBm</b>	-	140	-	mA
<b>Tx 802.11n, MCS7, POUT =+13dBm</b>	-	120	-	mA
<b>Rx 802.11b, 1024 bytes packet length , -80 dBm</b>	-	50	-	mA
<b>Rx 802.11g, 1024 bytes packet length , -70 dBm</b>	-	56	-	mA
<b>Rx 802.11n, 1024 bytes packet length , -65 dBm</b>	-	56	-	mA
<b>Modem-sleep①</b>	-	20	-	mA
<b>Light-sleep②</b>	-	2	-	mA
<b>Deep-sleep③</b>	-	20	-	uA
<b>Power Off</b>	-	0.5	-	uA

### Notes:

- **Modem-sleep** is used when such applications as PWM or I2S require the CPU to be working. In cases where Wi-Fi connectivity is maintained and data transmission is not required, the Wi-Fi Modem circuit can be shut down to save power, according to 802.11 standards (such as U-APSD). For example, in DTIM3, when ESP8266EX sleeps for 300 ms and wakes up for 3 ms to receive Beacon packages from AP, the overall average current consumption is about 20 mA.

- **Light-sleep** is used for applications whose CPU may be suspended, such as Wi-Fi switch. In cases where Wi-Fi connectivity is maintained and data transmission is not required, Wi-Fi Modem circuit and CPU can be shut down to save power, according to 802.11 standards (such as U-APSD). For example, in DTIM3, when ESP8266EX sleeps for 300 ms and wakes up for 3 ms to receive Beacon packages from AP, the overall average current consumption is about 2 mA.
- **Deep-sleep** is for applications that do not require Wi-Fi connectivity and only transmit data over long time lags, e.g., a temperature sensor that measures temperature every 100s. For example, when ESP8266EX sleeps for 300s then wakes up to connect to AP (taking about 0.3 ~ 1s), the overall average current consumption is far less than 1 mA. The current consumption of 20  $\mu$  A was obtained at the voltage of 2.5V.

## 4. Reflow Profile

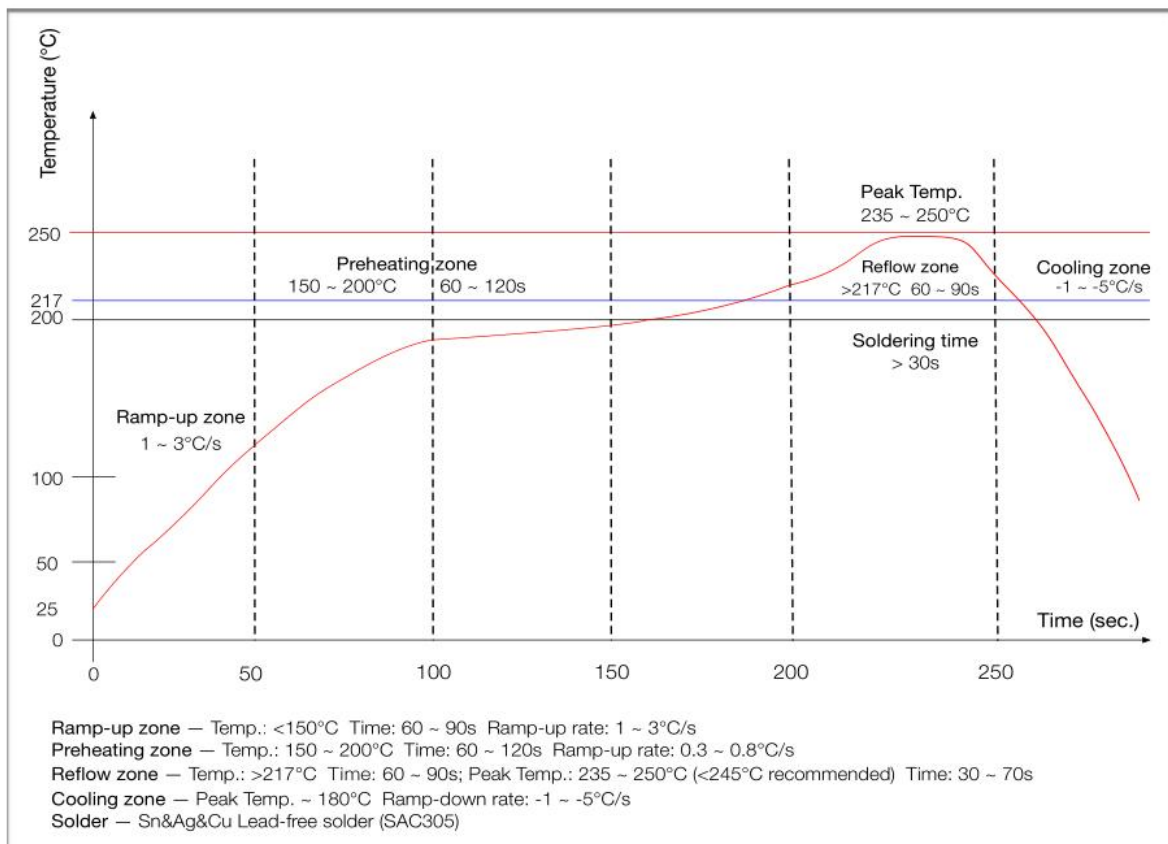

## 5. Application circuit

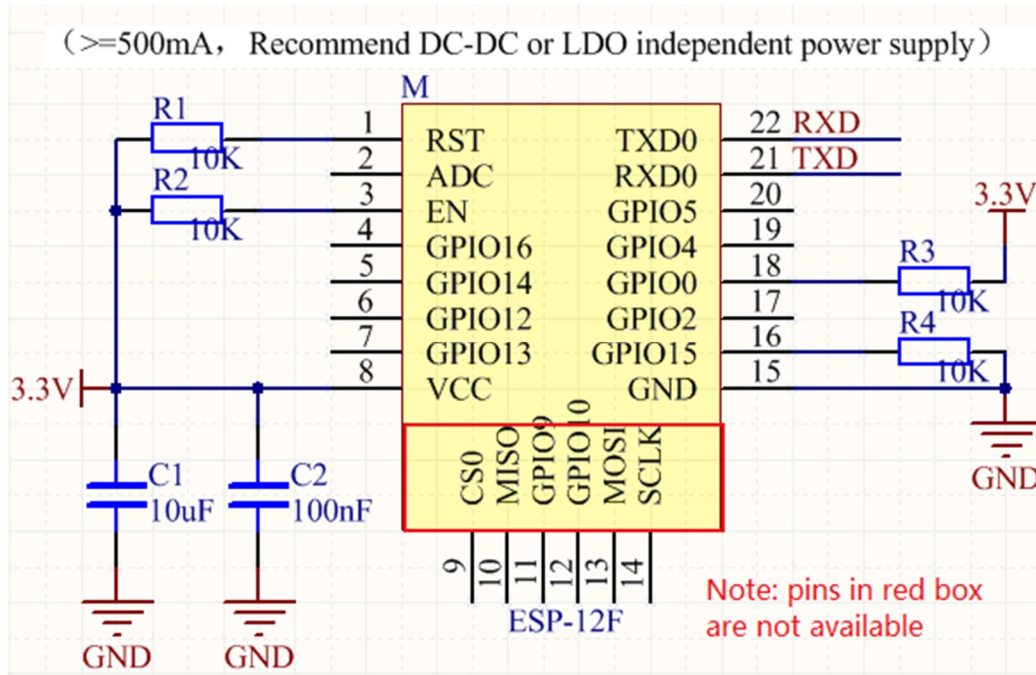

## 6. Schematics

