

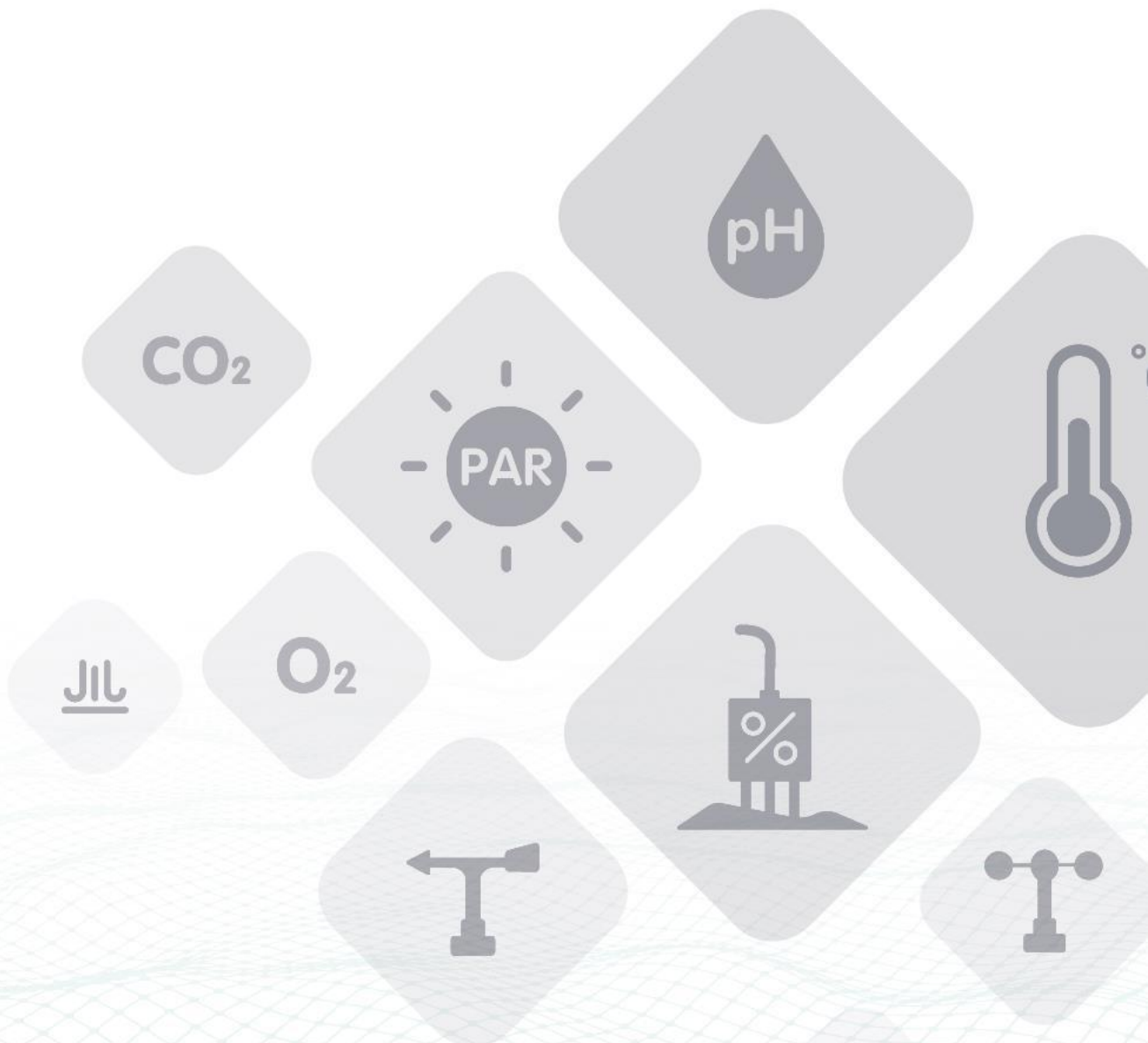

SENSECAP

Wio-SX1262 LoRa[®] Module

Version: V1.1



Content

1.	Introduction.....	3
1.1	Features.....	3
1.2	Model Information.....	3
2.	Specification.....	4
2.1	Pinout.....	5
3.	Electrical Characteristics.....	6
3.1	Absolute Maximum Ratings.....	6
3.2	Operating Range.....	6
3.3	Module Specifications.....	6
4.	Typical RF Performance Test.....	8
4.1	Wio-SX1262 Performance Testing.....	8
5.	Application Information.....	11
5.1	Package Information.....	11
5.2	External Interface of the Module.....	12
5.3	Reference Design Based on Wio-SX1262 Module.....	12
6.	LoRaWAN Application.....	13
7.	Reflow Soldering Parameters.....	14

1. Introduction



The Wio-SX1262 is a low-cost, ultra-low-power, and ultra-compact LoRa® Pure RF module. Embedded with the high-performance Semtech SX1262 LoRa® wireless communication IC, it is designed for wireless sensor networks and other IoT devices, especially those requiring battery-powered, low-power consumption, and long-range connectivity. Ideal for applications such as wireless meter reading, agriculture sensor, LoRaWAN single channel gateway etc.

This specification mainly describes the hardware information, hardware performance and application information of the module.

1.1 Features

- **Low Power Consumption:** as low as 1.62uA sleep current
- **Low Cost and High performance**
- **Small Size:** 11.6mm X 11mm * 2.95mm @12 pins SMT
- **Onboard RF Interface:** Default IPEX port
- **Support long-distance transmission:**
 - TXOP=22dBm@862-930MHz
 - -136.73dBm sensitivity for SF12 with 125KHz BW, included line loss
- **SPI Interface**

1.2 Model Information

Part Number	TX Power
Wio-SX1262	22dBm@HF (862-930MHz) with IPEX

2. Specification

The Wio-SX1262 module is based on SX1262, making it ideal for designing various IoT nodes. It supports both (G)FSK and LoRa® modulations, with a bandwidth range of 7.8 to 500 kHz in LoRa® mode. The module provides the SPI interface for communication with an external MCU. Its power distribution scheme supports two hardware options: DC-DC or a linear regulator LDO, and the Wio-SX1262 module utilizes the DC-DC design. Additionally, it features a high-precision active TCXO as its internal RF reference frequency, with DIO3 serving as the TCXO voltage power supply.

Schematic Diagram:

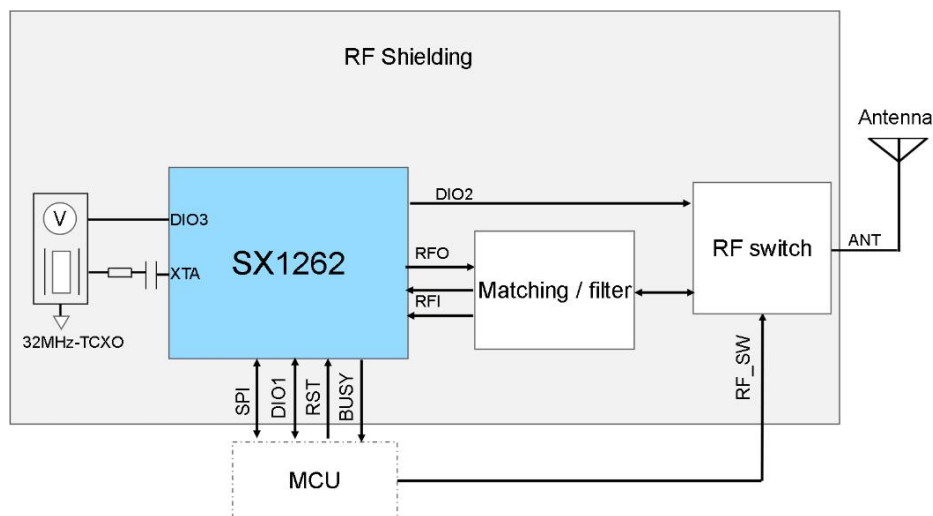

Figure 1 Wio-SX1262 Schematic Diagram

2.1 Pinout

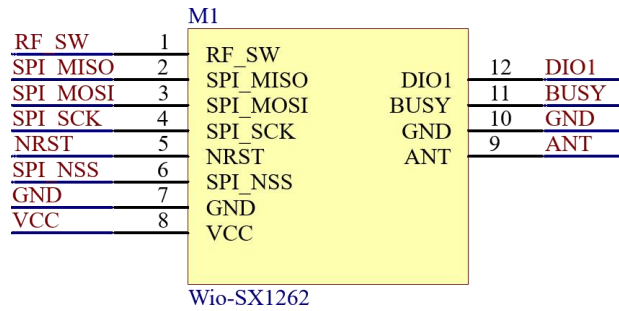

Figure 2 Wio-SX1262 Pinout

Number	Name	Type	Description
1	RF_SW	I	External IO control internal gate RF switch ^[1] .
2	MISO	I/O	SPI_MISO
3	MOSI	I/O	SPI_MOSI
4	SCK	I/O	SPI_SCK
5	NRST	I	Reset signal, active low
6	NSS	I/O	SPI_NSS
7	GND	-	Ground
8	VCC	I	Supply voltage for the module
9	ANT	I/O	RF input/output, NC ^[2]
10	GND	-	Ground
11	BUSY	O	Busy indicator of IC SX1262
12	DIO1	I/O	Multi-purpose digital IO, DIO1 of IC SX1262

[1] The switch between transmit and receive modes on the Wio-SX1262 module is determined solely by the voltage level on the SX1262's DIO2 pin (DIO2 HIGH = transmit mode; DIO2 LOW = receive mode).

[2] The RF pin defaults to the IPEX interface and does not require soldering. If you need an RF SMT Pin version, please contact our sales team.

3. Electrical Characteristics

3.1 Absolute Maximum Ratings

Reaching or exceeding the maximum ratings in the table below can cause equipment damage.

Item	Description	min	max	unit
VCCmr	Supply voltage	-0.5	+3.9	V
Tmr	Working temperature	-40	+85	°C
Tstore	Storage temperature	-40	+105	°C
Pmr	RF input level	-	+10	dBm

3.2 Operating Range

Item	Description	min	max	unit
VCCop	Supply voltage	+1.8	+3.6	V
Top	Working temperature	-40	+85	°C
Pop	RF input power	-	0	dBm

3.3 Module Specifications

Items	Parameter	Specifications	Unit
Structure	Size	11.6(W) X 11(L) X 2.95(H)	mm
	Package	12 pins, SMT	
Electrical Characteristics	Supply voltage	3.3V @typical	V
	Sleep current	1.62	uA
	SX1262 power distribution mode	DC-DC Mode	
	TCXO supply mode	By SX1262 DIO3	
	TCXO supply voltage	1.7~3.3	V
	Frequency range	HF@862-930	MHz
	Maximum operation current (Transmitter)	125mA @22dBm in 862-930MHz typical	mA
	Maximum operation current (Receiver)	7.6mA @BW125kHz, 862-930MHz typical	
	Output power	22dBm max @862-930MHz	dBm
Receiver Sensitivity	@SF12, BW125kHz	dBm	

	included line loss	Frequency (MHz)	min	typical	max	
		862-930	-	-136.73	-136.73	
	Harmonics @HF	≤-45dBm above 1GHz				dBm
Interface	ANT	RF port of IPEX or SMT pin, default IPEX @50-ohm impedance				
	DIO1	Multi-purpose digital IO				
	Busy	Busy signal indicator				
	SPI	1 group of SPI, include 4 pins				
Other	DIO2	Multi-purpose digital IO, internally connected to RF switch Logic high=Enable Transmitter mode, other mode =low level				
	DIO3	DIO3 is used as TCXO voltage power supply configure through software, TCXO voltage should always be 200 mV less than the VCC to ensure proper operation				

4. Typical RF Performance Test

4.1 Wio-SX1262 Performance Testing

RF Power

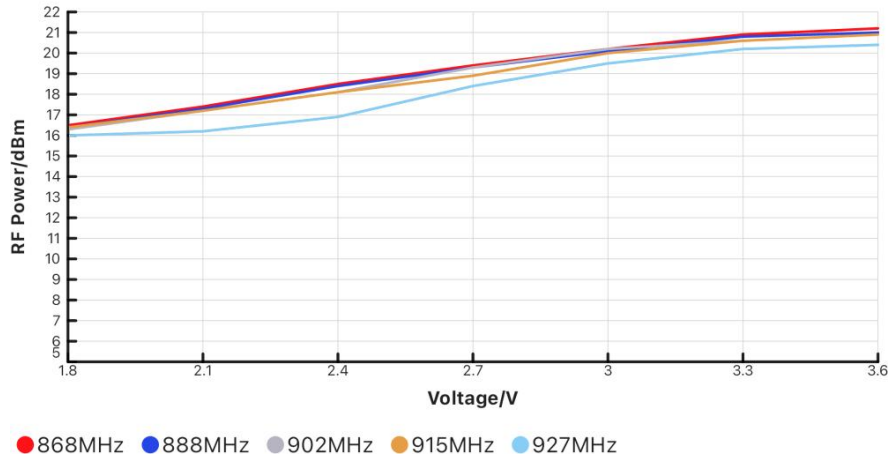

Figure 3 Max RF Power vs Voltage (868~927MHz)

RF Power

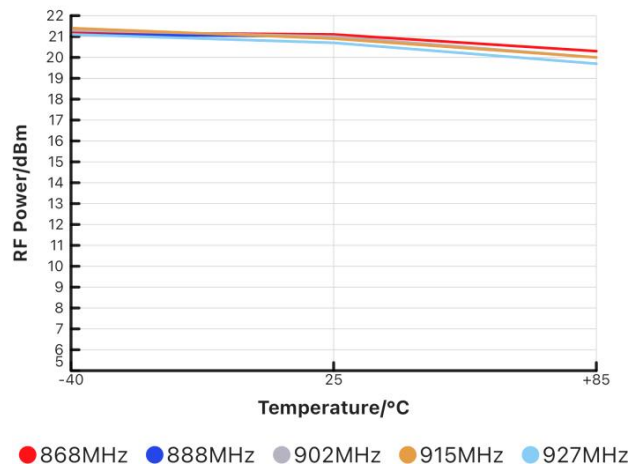

Figure 4 Max RF Power VS Temperature (868~927MHz)

RF Power

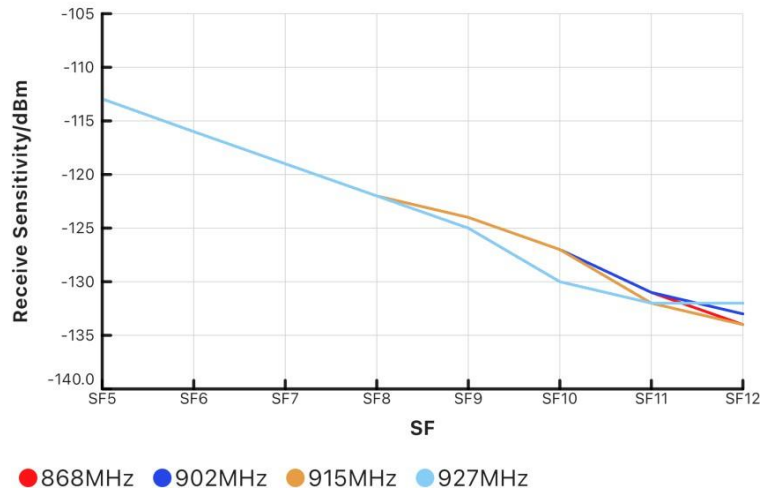

Figure 5 RF Receiver Sensitivity vs Spreading factor (868~927MH@BW125KHzz)

RF Receive Sensitivity

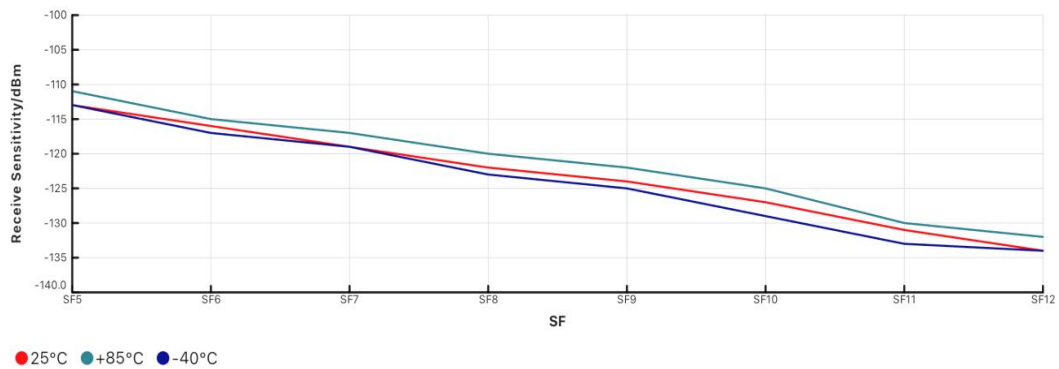

Figure 6 RF Receiver Sensitivity VS Temperature (868MHz@BW125KHz)

RF Receive Sensitivity

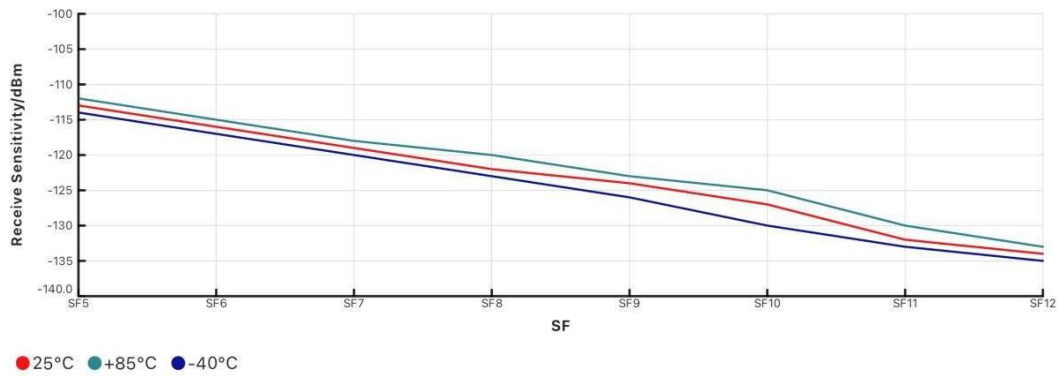

Figure 7 RF Receiver Sensitivity VS Temperature (915MHz@BW125KHz)

5. Application Information

5.1 Package Information

Unless specified dimension tolerance, the dimension below will be with tolerance $\pm 0.2\text{mm}$, all the dimension units are mm.

Wio-SX1262 has a 12-pins SMD package:

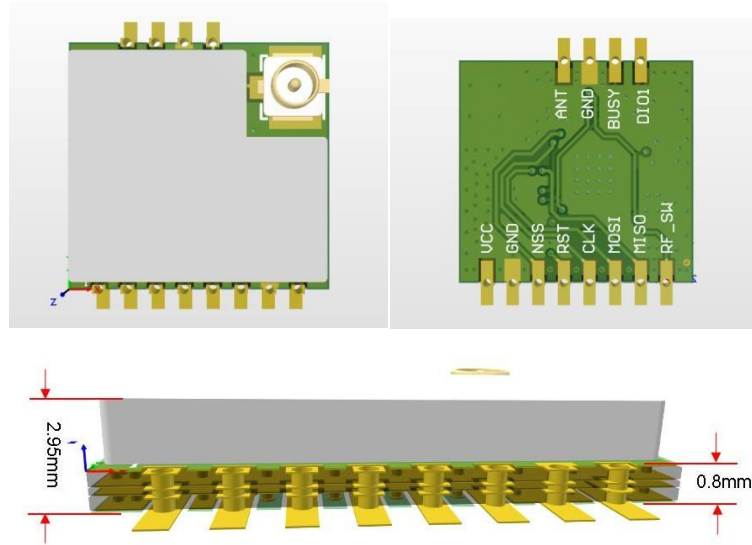

Figure 8 Wio-SX1262 Module Appearance

The following figure shows the recommended Layout package dimensions.

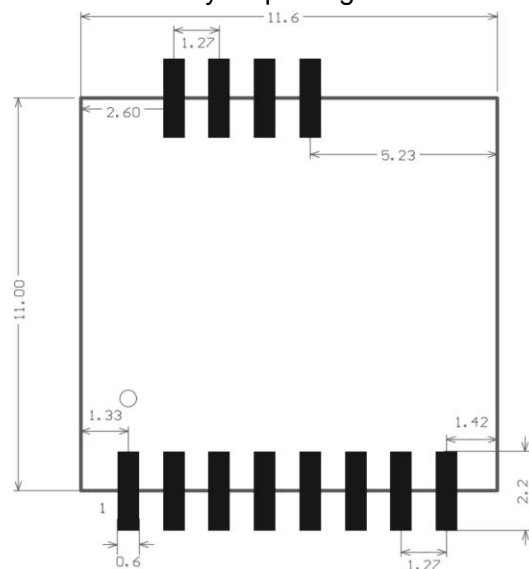

Figure 9 PCB Footprint

5.2 External Interface of the Module

- A set of SPI used for internal RF transceiver control
- DIO1 is the generic IRQ line
- An External GPIO used for control internal gate RF switch
- Busy is used as a busy signal indicating that the module is ready for new command only if this signal is low.
- The output impedance of the RF is 50 Ω and compatible with IPEX and SMT-Pin. IPEX is the default, and RF SMT-Pin does not require soldering. If you need the RF SMT-Pin version, please contact our company.

5.3 Reference Design Based on Wio-SX1262 Module

The following is a typical reference design using the Wio-SX1262 module, just connect the module to the host MCU according to the reference design.

Antenna design considerations: The antenna interface is designed with a 50 Ω impedance, and it is recommended that users reserve a π -type matching network for the antenna.

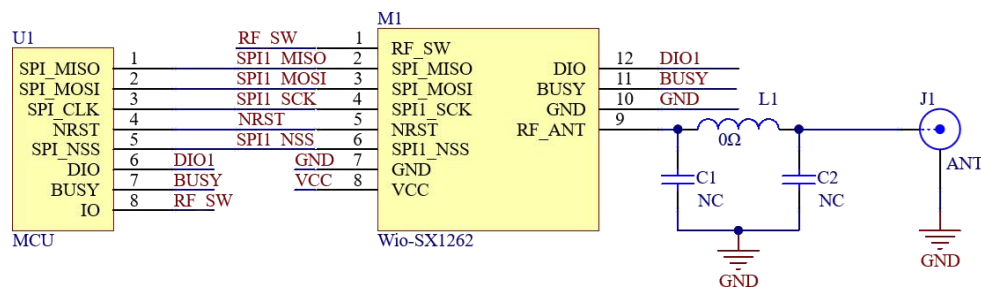

Figure 10 Reference Design Based on Wio-SX1262

6. LoRaWAN Application

The topology of the LoRaWAN® network is a star network, and the gateway acts as a relay between nodes and network servers. The gateway is connected to the network server through a standard IP link, and the node device uses LoRa® or FSK to communicate with one or more gateways. Communication is bidirectional, although it is mainly upstream communication from the node to the network server.

The communication between the node and the gateway uses different frequencies and rates. The choice of rate is a compromise between power consumption and distance, and different rates do not interfere with each other. According to different spreading factors and bandwidths, the rate of LoRa® can be from 300bps to 50Kbps. To maximize battery life and network capacity, the network server manages the node's rate and output power through rate adaptation (ADR).

The node device may transmit on a random channel at any time and at any rate, as long as the following conditions are met:

- 1) The channel currently used by the node is pseudo-random. This makes the system more resistant to interference.
- 2) The maximum transmission time (dwell time of the channel) and duty cycle of the node depends on the frequency band used and local regulations.

Wio-SX1262 pure RF module only a simple MCU is needed as the main controller to control Wio-SX1262 through SPI interface, thereby easily implementing the LoRaWAN® protocol. This helps customers quickly bring sensor products to the LoRaWAN® market.

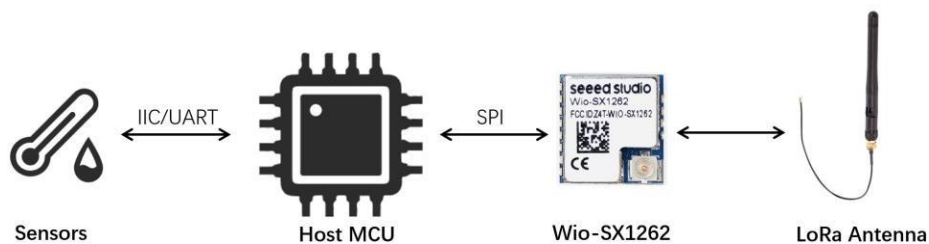

Figure 11 Design of LoRaWAN® wireless sensor based on Wio-SX1262 module

7. Reflow Soldering Parameters

The design of the Wio-SX1262 module makes it very convenient for production, including soldering it to PCB boards using reflow soldering technology. A basic element is that users need to choose the appropriate solder paste and ensure that the solder paste meets the temperature requirements during the furnace passing process. Wio-SX1262 complies with the requirements of J-STD-020D1 standard for reflow soldering temperature.

Note: It is recommended that the module undergoes only one reflow soldering, and the temperature of the module should not exceed 260 °C during reflow soldering. The reflux period should not exceed 30 seconds.

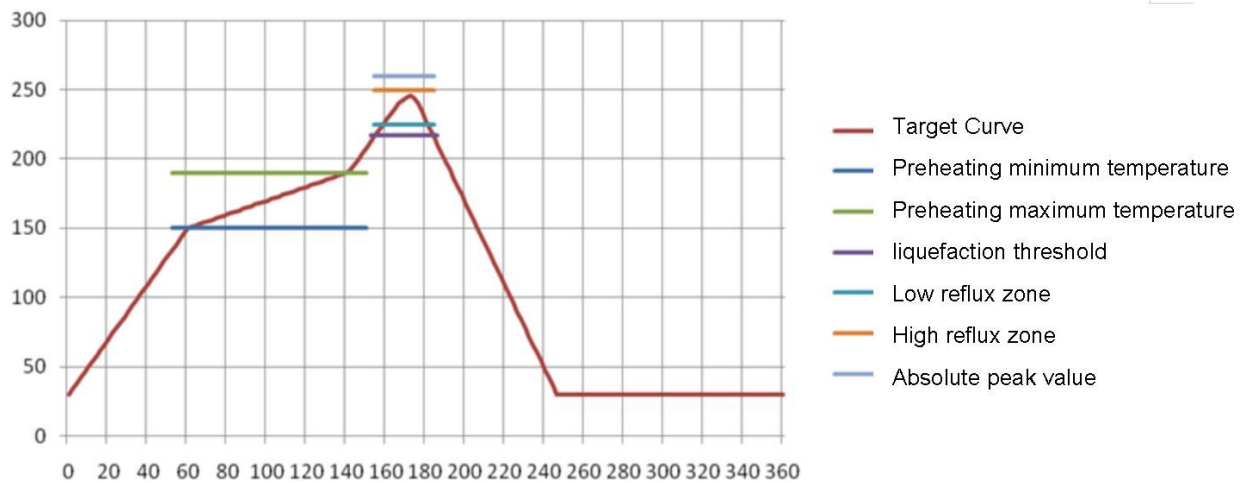

Figure 12 Reflow profile

Item	value	Unit
Heating rate	1~3	°C/Sec
Cooling rate	2~4	°C/Sec
Heating rate of preheating zone	0.5~1	°C/Sec
Preheating zone length MIN	70	Sec
Preheating zone length MAX	120	Sec
Preheating temperature MIN	150	°C
Preheating temperature MAX	190	°C
Residence time of solder paste above the liquefaction temperature MAX	70	Sec
Residence time of solder paste above the liquefaction temperature MIN	50	Sec
Residence time in the reflux zone	30	Sec
Peak temperature residence time	5	Sec

MAX		
Suggested liquefaction zone threshold	218	°C
Low point temperature of reflux zone	240	°C
High point temperature in the reflux zone	250	°C
Absolute peak temperature	260	°C

8. ODM & OEM Services

With decades of ODM & OEM experience, our engineers and product experts are proficient in delivering customization service for popular open-source hardware platforms – NVIDIA® Jetson™, Raspberry Pi®, Beagleboard®, and more. Use the LoRa® module to create industrial-grade sensors or development boards for rapid AIoT implementation.

We're dedicated to supporting you and streamlining your idea-to-product journey. We are ready to bring your product concept to the market with Seeed Studio's industrial capabilities from design, manufacturing, testing, certification, global distribution, and marketplace. To design with the LoRa® module, please contact iot@seeed.cc